

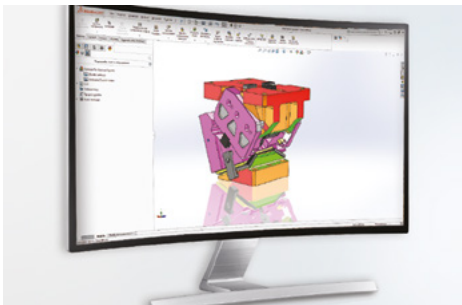

Cam Units DLD
Schieber DLD
Unità a Camme DLD

OMCR[®]
STANDARD DIE COMPONENTS

OMCR CODE	Work Angle	Slider Width (mm)	Closed Cam Height (mm)	Work Area W x H (mm)	Max Work Force with shoulder 10 ⁶ cycles (kN)	Extraction Force (kN)	Page number
	β				F _s	F _t	
DLD052	0÷20° (5° steps)	52	215÷255	52x75	40	0,53	906
DLD090	0÷15° (5° steps)	90	220÷225	90x82	79	1,05	910



Dynamic technical staff and advanced design methods

DIE MOUNTED CAM UNIT - HORIZONTALSCHIEBER - UNITÀ A CAMME A BASE STAMPO

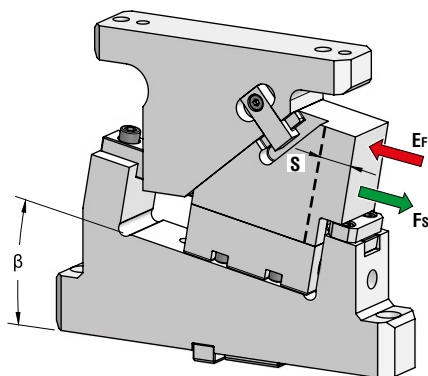

OMCR CODE	Work Angle	Stroke (mm)	Max Work Force with shoulder (kN)	Extraction Force (kN)	
	β			S	Fs
DLD052.00.55	0°	55	40	0,53	
DLD052.05.55	5°	55	40	0,53	
DLD052.10.55	10°	55	40	0,53	
DLD052.15.55	15°	55	40	0,53	
DLD052.20.55	20°	55	40	0,53	

OPTION CODE	
SL	5 ÷ 65 (5mm steps)
SW	100 mm



Art.	Work Angle = 5°	Stroke = 55	OPTION CODE	
			SL	SW
DLD052	05	55	SL55	SW100

OMCR CODE	Work Angle	Stroke (mm)	Overall Dimensions (mm)													
	β		S	A	B	C	D	E	F	G	H	I	J	K	L	M
DLD052.00.55	0°	55	220	170	0	210	215	235	45	145	65	105	90	160	160	210
DLD052.05.55	5°	55	269,87	195,66	35	260	255	310	15	280	110	110	140	175	175	225
DLD052.10.55	10°	55	279,75	195,02	35	270	255	310	15	280	110	110	140	185	185	235
DLD052.15.55	15°	55	289,51	193,09	40	280	255	310	15	280	110	110	140	190	190	240
DLD052.20.55	20°	55	304,05	174,88	55	295	255	310	15	280	110	110	140	190	190	240

DIE MOUNTED CAM UNIT - HORIZONTALSCHIEBER - UNITÀ A CAMME A BASE STAMPO

X VIEW

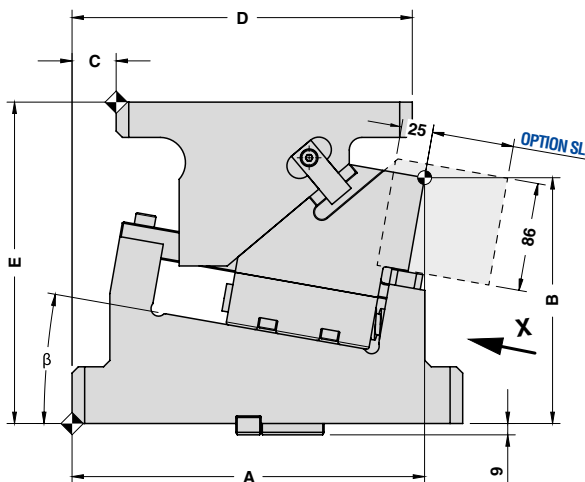
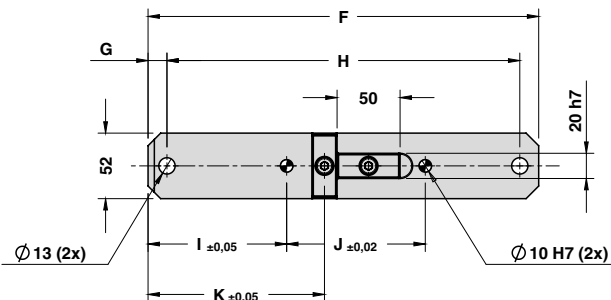
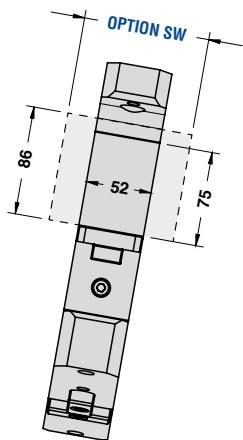

CAM DIAGRAM

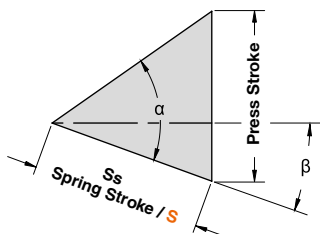

Work Angle	Inner Angle	Slider Work Stroke (mm)	Press Stroke (mm)	Spring Stroke (mm)
β	α	S	Ps	Ss
0°	50°	55	65,55	55
5°	50°	55	59,58	55
10°	50°	55	55,00	55
15°	50°	55	51,43	55
20°	50°	55	48,65	55

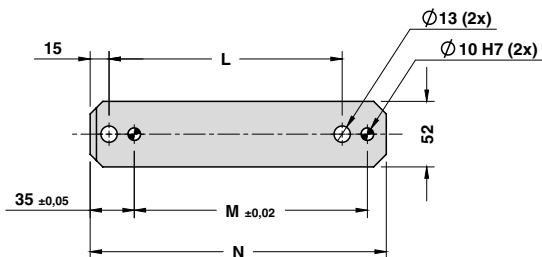

Cam Units DLD

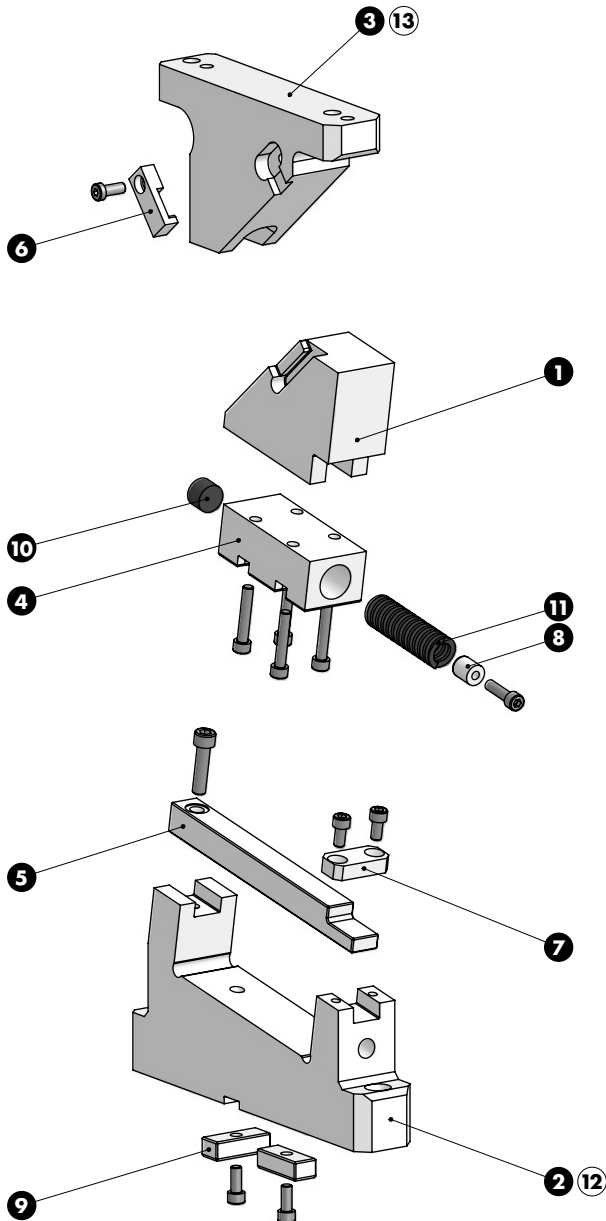
DIE MOUNTED CAM UNIT - HORIZONTALSCHIEBER - UNITÀ A CAMME A BASE STAMPO

DIE MOUNTED CAM UNIT - HORIZONTALSCHIEBER - UNITÀ A CAMME A BASE STAMPO

SLIDER STRUCTURE, POSITIVE RETURN STRUCTURE AND CLEARANCES

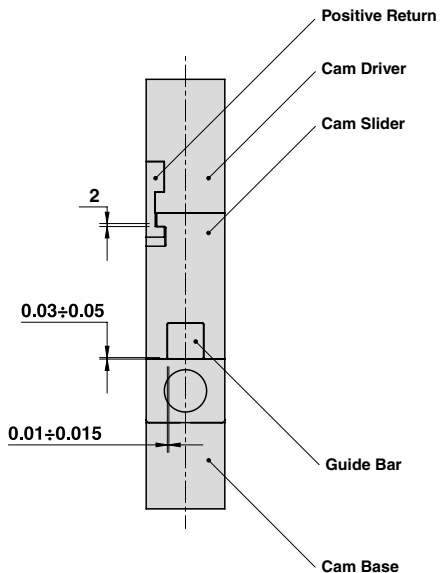

Cam Units DLD

PART LIST

Particular number	Description	Material	Quantity
1	Cam Slider	GG-25	1
2	Cam Base	GG-25	1
3	Cam Driver	GG-25 + Graphite	1
4	Spring Guide Block	GG-25 + Graphite	1
5	Guide Bar	42CrMo4 + Graphite	2
6	Positive Return	CK45	1
7	Guide Bar Stopper Plate	CK45	1
8	Spring Guide Pin	CK45	1
9	Key	CK45	2
10	Elastomer Cap	Elastomer 92SH	1
11	Spring	-	1
12	Cam Base Fixing Screws M12x45 DIN 912	-	2
13	Cam Driver Fixing Screws M12x45 DIN 912	-	2

DIE MOUNTED CAM UNIT - HORIZONTALSCHIEBER - UNITÀ A CAMME A BASE STAMPO

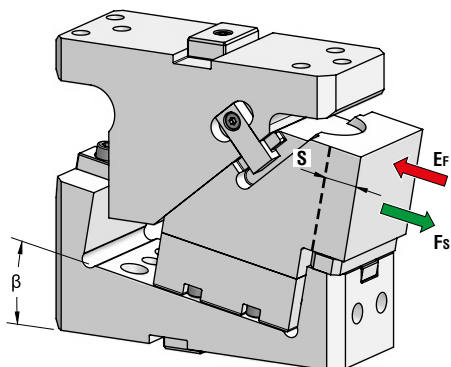

OMCR CODE	Work Angle	Stroke (mm)	Max Work Force with shoulder (kN)	Extraction Force (kN)
	β	S	F _s	E _f Spring
DLD090.00.55	0°	55	79	1,05
DLD090.05.55	5°	55	79	1,05
DLD090.10.55	10°	55	79	1,05
DLD090.15.55	15°	55	79	1,05

OPTION CODE	
SW	120 or 150 mm
N	Ø 12H7



Art.	Work Angle = 5°	Stroke = 55	OPTION CODE	
			SW	N
DLD090	05	55	SW120	N12

OMCR CODE	Work Angle	Stroke (mm)	Overall Dimensions (mm)								
	β	S	A	B	C	D	E	F	G	L	M
DLD090.00.55	0°	55	236	182	0	210	220	233	60	210	160
DLD090.05.55	5°	55	251,42	166,24	0	225	220	240	60	225	175
DLD090.10.55	10°	55	261,72	164,14	0	235	220	243	60	235	185
DLD090.15.55	15°	55	275,82	160,97	15	250	225	248	65	235	185

DIE MOUNTED CAM UNIT - HORIZONTALSCHIEBER - UNITÀ A CAMME A BASE STAMPO

X VIEW

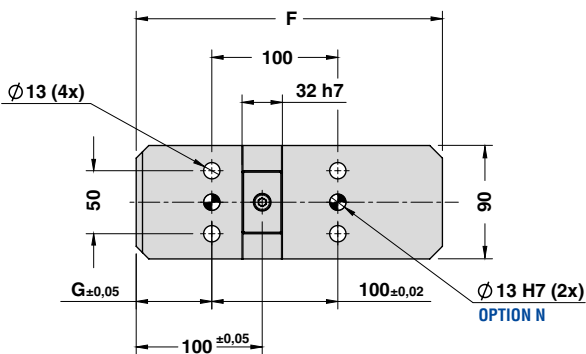
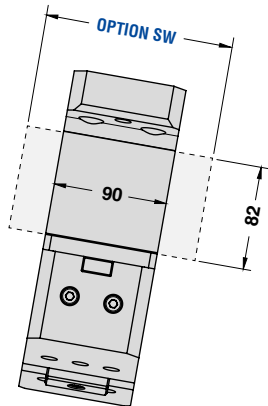

CAM DIAGRAM

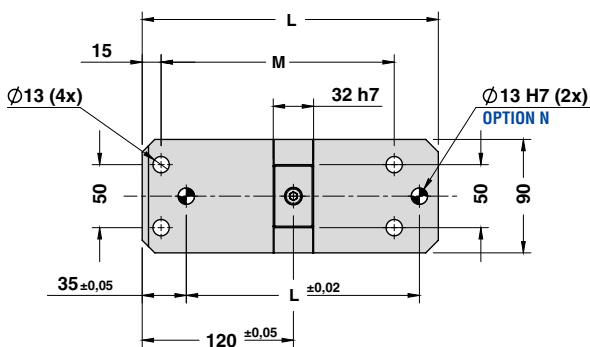
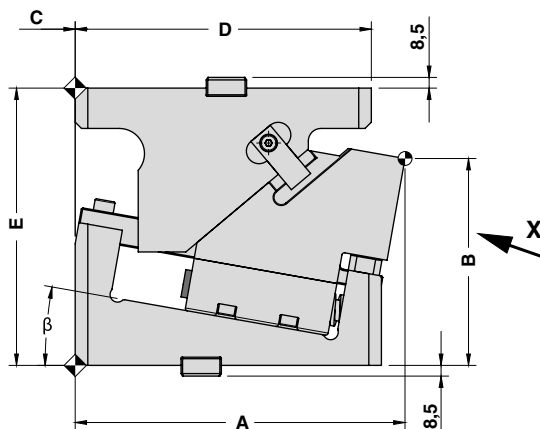
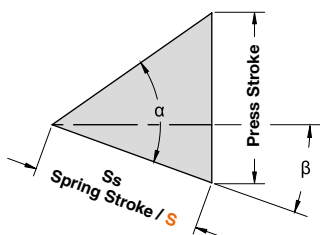

Work Angle	Inner Angle	Slider Work Stroke (mm)	Press Stroke (mm)	Spring Stroke (mm)
β	α	S	Ps	Ss
0°	50°	55,00	65,55	55
5°	50°	55,00	59,58	55
10°	50°	55,00	55,00	55
15°	50°	55,00	51,43	55

DIE MOUNTED CAM UNIT - HORIZONTALSCHIEBER - UNITÀ A CAMME A BASE STAMPO

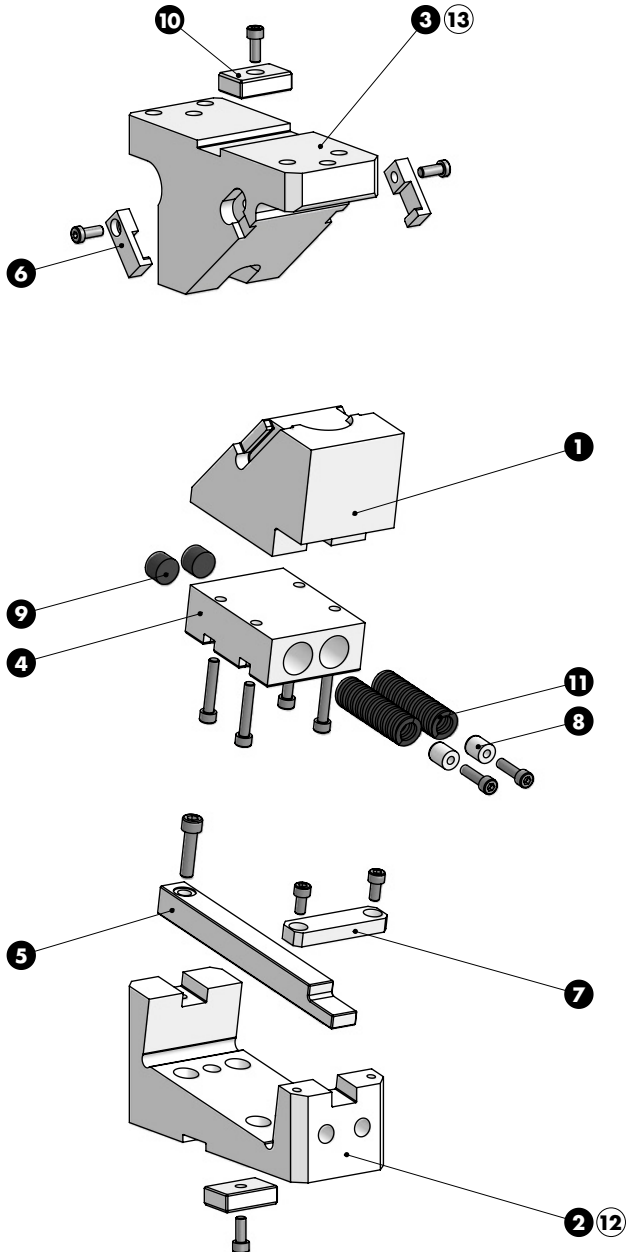

DIE MOUNTED CAM UNIT - HORIZONTALSCHIEBER - UNITÀ A CAMME A BASE STAMPO

SLIDER STRUCTURE, POSITIVE RETURN STRUCTURE AND CLEARANCES

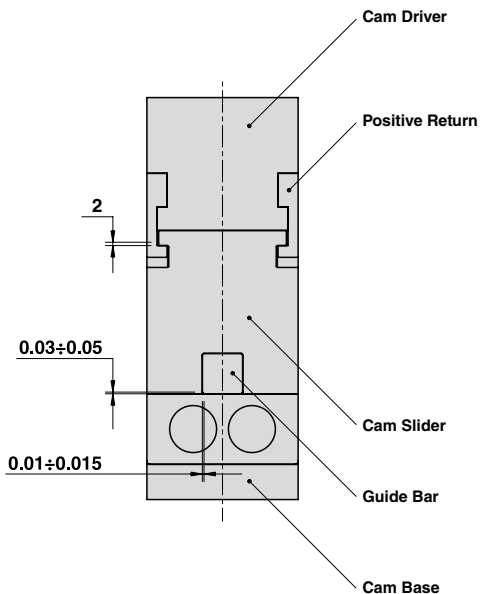

Cam Units DLD

PART LIST

Particular number	Description	Material	Quantity
1	Cam Slider	GG-25	1
2	Cam Base	GG-25	1
3	Cam Driver	GG-25 + Graphite	1
4	Spring Guide Block	GG-25 + Graphite	1
5	Guide Bar	42CrMo4 + Graphite	1
6	Positive Return	CK45	2
7	Guide Bar Stopper Plate	CK45	1
8	Spring Guide Pin	CK45	2
9	Key	CK45	2
10	Elastomer Cap	Elastomer 92SH	2
11	Spring	-	2
12	Cam Base Fixing Screws M12x45 DIN 912	-	4
13	Cam Driver Fixing Screws M12x45 DIN 912	-	4

